

KOMATSU

WA
500



WA500-3

WA500-3

WHEEL LOADER

**FLYWHEEL
HORSEPOWER**
235 kW 315 HP

OPERATINGWEIGHT
30.000 kg

BUCKETVOLUME
4,5 - 5,5 m³

AT A GLANCE

Powerful, rugged, environmentally friendly and comfortable: The new WA500-3 is the perfect choice for all heavy-duty work. Equipped with the Komatsu SA6D140E-3 low emission engine with common rail fuel injection, this exceptionally robust wheel loader offers maximum power output. The new driver's cab is one of the most spacious in its class and, in addition to unsurpassed driving comfort, it provides an optimum view of the bucket and wheels.

Reliability, ease of service and economy - the new WA500-3 sets the standard in profitability and efficiency.

Newly designed *spacious driver's cab* with angular windows for excellent visibility and perfect operating comfort. Standard features such as *air conditioning* and *joystick steering control* (optional) ensure a stress-free and productive working day. The noise emission level in the driver's cab is just 77 dB(A) conforming to 95/27/EC. (Page 8)

Fast bucket loading/unloading operations, high breakout force and excellent dumping height with *tough mono-cylinder Z-kinematics* and *two-stage APS hydraulic system*. (Page 5)

Efficient material handling in rehandling and quarry applications: 3 bucket loads fill a 40 tonne semitrailer truck. (Page 10)



Durable, wear-resistant buckets from the comprehensive range of equipment. (Page 12)

WA500-3

WHEEL LOADER

FLYWHEEL HORSEPOWER

235 kW 315 HP

OPERATING WEIGHT

30.000 kg

BUCKET VOLUME

4,5 - 5,5 m³



Powerful and efficient *Komatsu low emission engine* with electronic-map common rail fuel injection system. Complies with the European exhaust emission regulations as stipulated in TIER II. (Page 4)

Standard features including *central lubrication system, maintenance-free multi-disc brakes* and a *500 h engine oil change interval* guarantee minimum service expenditure. (Page 7)

Extremely strong body mounted on the *sturdy axles, torsionally rigid frame* and the *planetary transmission* ensure a long service life even under the toughest working conditions. (Page 4)

RUGGED, POWERFUL & RELIABLE



Powerful low emission engine

The powerful, high-torque Komatsu low emission engine SA6D140E-3 develops 235 kW/ 315 HP. The state-of-the-art, electronic common rail fuel injection system with characteristic-map control ensures exceptionally low fuel consumption and complies with the latest European exhaust emission regulations as stipulated in TIER II.



Heavy-duty, reliable drive train

The rugged HD axles with planetary reduction in the wheel hubs and the sturdy powershift transmission based on planetary design guarantee above-average durability even under the most rugged operating conditions.

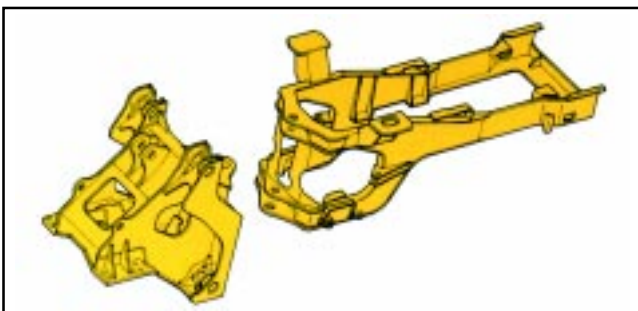

Torsionally rigid frame

The frame design with pivot points set far apart ensures stability of the overall structure while reducing bearing loads in the articulated joint. 40° steering angle for efficient manoeuvrability.



Sturdy lift frame

The lift frame with powerful Z-kinematics makes for maximum breakout forces. Solid material cross sections and large pin diameters enhance the outstanding load bearing capacity of the overall machine.



Exceptional stability

With a track width of 2,400 mm and a long wheelbase of 3,600 mm, the WA500-3 offers outstanding stability in all operating situations.

Powerful and fast loading cycles with the APS hydraulic system

The APS system is an effective working hydraulic system that adapts automatically to individual operating conditions and reduces cycle times. A quick-action hydraulic system is always required wherever the shortest possible loading cycles are demanded in confined spaces. Under these conditions, the main and auxiliary pump together provide a high delivery rate ensuring fast bucket lift. However, maximum power is required for loading and material breakout operations. At this point, the main pump alone delivers the oil flow. Increased engine power is now made available to the transmission for powerful penetration into the material and to the hydraulics for increased breakout force.

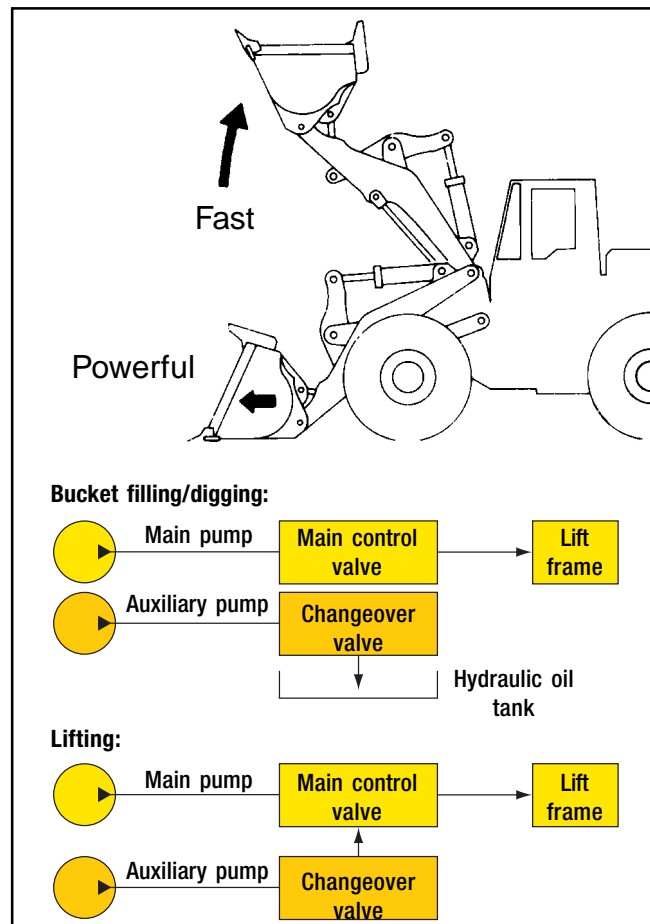

SIMPLE AND FAST SERVICING



Easy and convenient maintenance access

The service doors provide convenient and safe access to the daily check and service points from the ground.



The service monitor

The monitor system of the WA500-3 features a separate service monitor for displaying all service data. The system includes a fault code memory and self-diagnosis function to considerably reduce the time required for service work.



Maintenance-free brake system

The fully hydraulic dual circuit service brake system with multi-disc brakes running in oil ensures maximum safety and a long service life. Added to this, metering of the brake system is exceptionally responsive, while its fully hydraulic operating principle effectively eliminates the disadvantages of a compressed air brake system. Impervious to all weather conditions, immediately ready for operation as soon as the engine is started, and no maintenance - these are the advantages of the new system. The oil-immersed multi-disc parking brake is also completely maintenance-free.

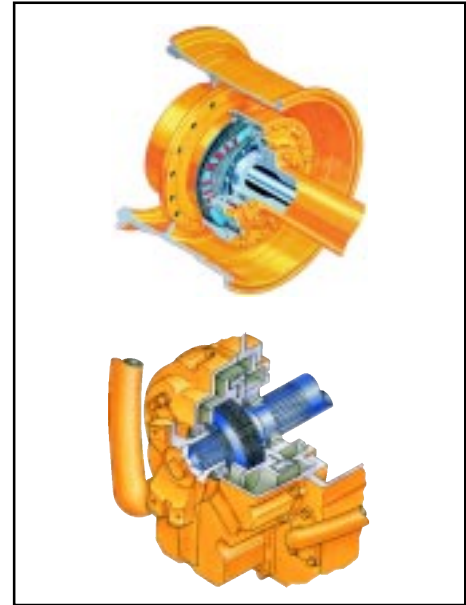

Central lubrication system as standard

The central lubrication system reduces daily servicing jobs to the absolute minimum. The robust installation, incorporating protection devices in all critical areas, permanently ensures exact lubricant metering and operational reliability in addition to electronic monitoring with fault indication in the driver's cab. The operational availability and service life of the machine are increased, repair and maintenance costs reduced.



After-sales service and parts supply

When you purchase a Komatsu construction machine you get much more than just the product. Our service accompanies you during the entire life of your wheel loader. In addition to preventative maintenance programs, we also offer complete full-service agreements and extended warranties. And should a problem ever arise, the close-knit Komatsu dealer network and a 24-hour parts service guarantee minimum downtimes.



SPACIOUS DRIVER'S CAB



Perfect operating comfort and outstanding all-round view

The new driver's cab is the largest in its class and offers unsurpassed operating comfort on a par with passenger cars. The angular windows provide an optimum view of the bucket and wheels. The cab mounting on viscous dampers, a low interior noise level and the air conditioning system fitted as standard contribute to the well-being of the operator, as do the air-cushioned driver's seat, and the ergonomically positioned, soft-touch controls. The operator feels comfortable and alert over long, productive hours!

SIMPLE & CONVENIENT OPERATION

Adjustable steering column with integrated monitor unit

The fully adjustable steering column incorporates the main monitor. It can therefore always be set in the most favourable position and, together with the two-spoke steering wheel, it ensures a clear view of the indicator instruments and gauges.



Easy-to-use joystick steering (option)

An optionally available joystick steering facility ensures easy and convenient steering during loading operations with a flick of the wrist. With this system, the direction of travel is changed by means of buttons on the joystick, and gears can be shifted either by the automatic transmission or manually with the "Kick-down" and "Hold" switches on the hydraulic control lever.



Fast bucket filling for shorter cycle times

The kick-down switch drastically shortens the bucket filling time. At the push of a button, it shifts from 2nd to 1st gear and the maximum tractive force is immediately available. In load & carry operations, the kick-down can be activated at a speed of 13 km/h from any gear. 2nd gear is then automatically made available again for reversing.



Electronic automatic transmission

With the fully automatic KOMATSU transmission you can rest assured that the optimum gear ratio is selected depending on the travelling speed and load status. This feature saves fuel while reducing the stress and strain on components. During gearshifts, the clutch pressure is modulated so smoothly as to eliminate delays and jolts in gearshift operations.



Air-cushioned comfort driver's seat

The driver's seat features many adjustment options, is air-cushioned and equipped with a head restraint. Thanks to the large adjustment ranges, any driver will find the most comfortable seating position to suit him.



VERSATILE AND PRODUCTIVE

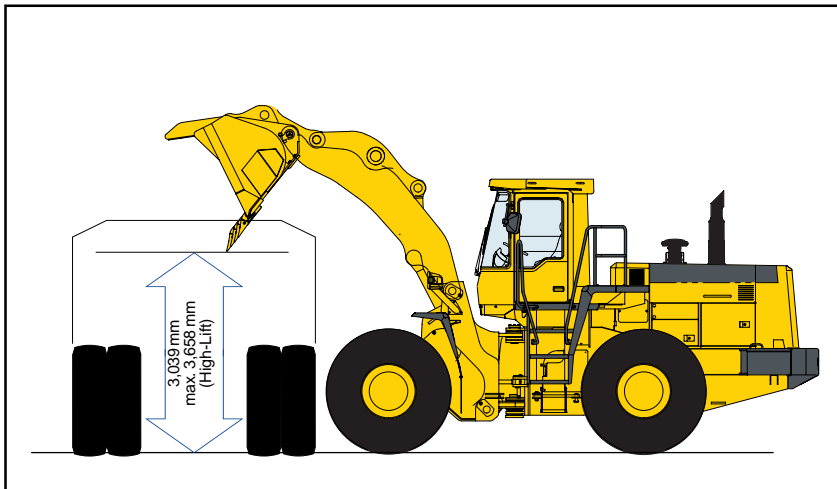

Easy loading

With the large dump height and reach it is possible to load 36 tonne special-purpose trucks in quarries without a hitch. The enormous rimpull, lift and breakout forces combine in executing this operation as efficiently as possible. In rehandling operations, 40 tonne semitrailer trucks can be efficiently filled in 3 bucket loads. The large dump height and reach as well as the adapted bucket volume of 5.5 m³ also come into their own for this application.



Faster material handling

High performance combined with robust design increases productivity in load & carry operations. Extremely short cycle times ensure high material handling rates at transport distances of up to 350 m, backed by the new, further improved ECSS load stabilizer: The material handling rate increases, the machine is effectively protected, thus reducing costs.



Maximum dumping height with High-Lift

With the optional High-Lift frame, the dump height and reach of the WA500-3 can be extended for special applications. With the dumping height increased by 40 cm and the reach extended by about 22 cm, 50 tonne special-purpose trucks can also be filled efficiently.



Comprehensive range of attachments

For example, working with the tree-clamp: with its stability and outstanding hydraulic power, the WA500-3 is also profitably used in the timber and forestry industries. Here, the heavy-duty versions of lifting gear, axles and auxiliary hydraulics guarantee safety in service and a long life.



Hydraulic quick-action coupler (option)

With the optionally available hydraulic quick-action heavy-duty coupler, the attachments on the WA500-3 can be changed within seconds; for example, from block handling with the ashlar fork to the rehandling bucket.



BUCKETS AND CUTTING TOOLS

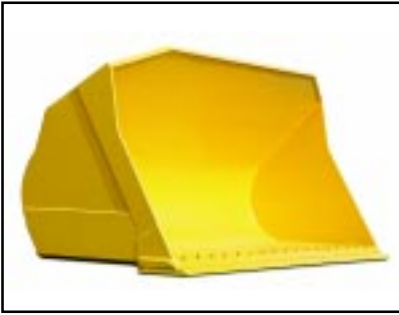

Universal buckets

This type of bucket with a long, flat bucket floor features an outstanding material retaining capacity. The universal bucket can be equipped with bolt on edges or flush mount adapters and interchangeable Hensley™ tooth bits. This type of bucket is optionally available with a rear-sided cutting edge.



Rock buckets

Four buckets with capacities ranging from 4.5 to 5.5 m³ are available for medium-duty rock and earthwork applications. The trapezoidal form supports outstanding material penetration. Welded or bolted wear plates made of rugged Hardox ensure a long service life.



Heavy-duty rock buckets

HD rock buckets with KVVX™ teeth as well as screw segments are available for highly abrasive rock material and earthwork. This extremely durable system as well as the optionally available stone deflectors guarantee maximum service life even under the most severe operating conditions.





Ultra-wear resistant ground engaging equipment – Lower costs per tonne

With the brands Komatsu KVX™ and Hensley™-Parts, Komatsu has extensive know-how, making it a leading supplier of GET in the global market. The comprehensive range of ultra-wear resistant teeth, segments and wear plates covers all applications even under the toughest working conditions. Many of the individual components are reversible so that they are simply turned round after one side has worn down. Improved material penetration capacity and lower bucket weight are reflected in reduced fuel consumption and lower tyre wear, thus distinctly increasing profitability and efficiency.



Up to 600 Brinell hardness

Hardening the steel after machining creates an optimum combination of hardness and abrasive strength, and therefore a significantly longer service life.



DIMENSIONS & PERFORMANCE FIGURES

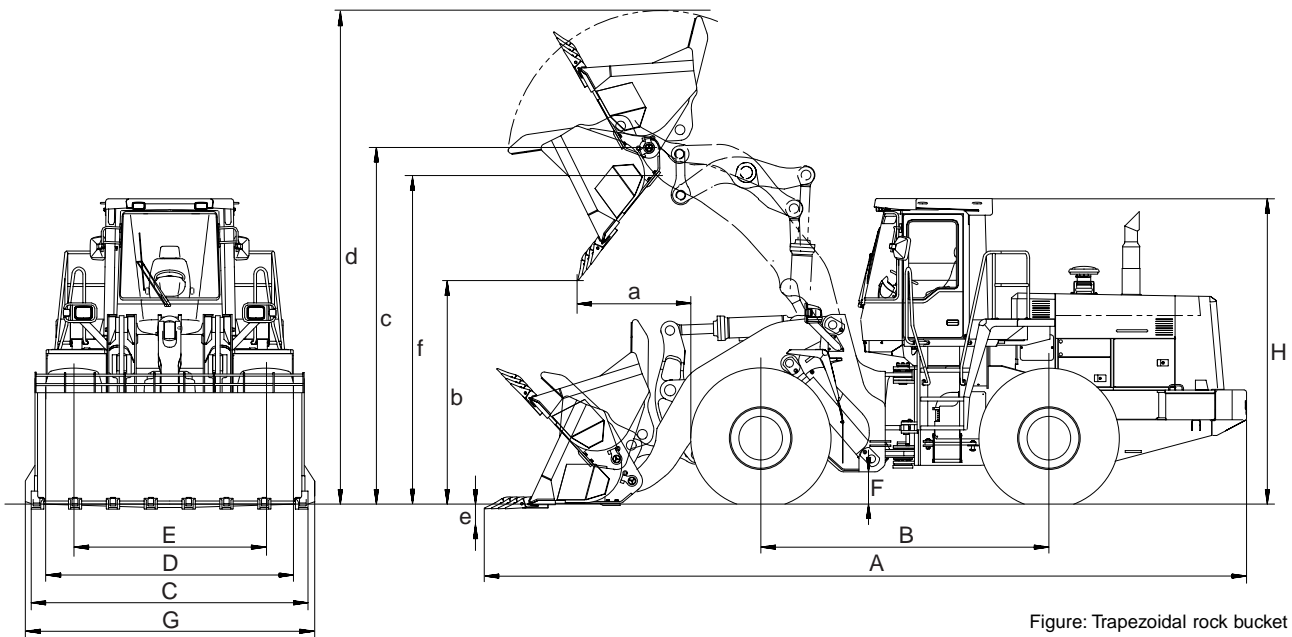

Figure: Trapezoidal rock bucket

Performance figures - bucket operation with 29.5 R25 L-3 tyres

Bucket type		Universal			Rock trapezoidal		High-Lift frame Rock trapezoidal	
		Universal	Universal	Universal	Universal	Universal	Universal	Rock trapezoidal
Bucket capacity (heaped, ISO 7546)	m ³	4,5	5,0	5,5	4,5	5,0	4,5	4,5
Material density	t/m ³	1,8	1,6	1,45	1,8	1,6	1,6	1,6
Bucket weight without teeth	kg	2.840	2.950	3.050	3.300	3.500	2.840	3.300
Static tipping load, straight	kg	23.564	23.400	23.268	23.104	22.850	20.370	19.910
Static tipping load, 40° articulated	kg	20.868	20.710	20.581	20.408	20.160	17.990	17.530
Breakout force hydraulic	kN	260,5	248	228	215	207	255,1	208,7
Lifting capability hydr. at ground level	kN	313	313	313	324	313	276,4	280,2
Operating weight (without add. counterw.)	kg	29.360	29.470	29.570	29.820	30.020	29.792	30.252
Turning radius at corner of tyres	mm	6.530	6.530	6.530	6.530	6.530	6.530	6.530
Turning radius at bucket edge	mm	7.302	7.322	7.361	7.302	7.322	7.492	7.492
a Reach at 45°	mm	1.274 ¹	1.323 ¹	1.415 ¹	1.486	1.535	1.490	1.702
b Dump height at 45°	mm	3.251 ²	3.195 ²	3.103 ²	3.039	2.983	3.658	3.446
c Hinge pin height	mm	4.496	4.496	4.496	4.496	4.496	4.910	4.910
d Height top edge of bucket	mm	6.072	6.160	6.263	6.229	6.160	6.470	6.643
e Digging depth	mm	124	124	124	124	124	194	194
f Overload height	mm	4.105	4.105	4.105	4.105	4.105	4.630	4.630
A Overall length, bucket grounded	mm	9.127 ³	9.197 ³	9.328 ³	9.427	9.497	9.675	9.975
B Wheelbase	mm	3.600	3.600	3.600	3.600	3.600	3.600	3.600
C Bucket width	mm	3.460	3.460	3.460	3.460	3.460	3.460	3.460
D Width over tyres	mm	3.190	3.190	3.190	3.190	3.190	3.190	3.190
E Track width	mm	2.400	2.400	2.400	2.400	2.400	2.400	2.400
F Ground clearance	mm	450	450	450	450	450	450	450
H Overall height	mm	3.860	3.860	3.860	3.860	3.860	3.860	3.860
G Width over stone deflectors	mm	-	-	-	3.650	3.650	-	3.650

Specifications for universal buckets without teeth, for version with teeth: ¹ + 222 mm / ² - 222 mm / ³ + 315 mm.
The vertical dimension changes by -60 mm when the machine is equipped with 26.5 R25 tyres.

Change in data caused by:

	Add. counter-weight	Tyre inflation (29.5 R25)	Equipment with teeth
Weight	kg	+1.000	+250
Stat. tipping load, straight	kg	+1.900	-250
Stat. tipping load, 40° angle	kg	+1.600	-270
Overall length (A)	mm	+141	-

with High-Lift frame:

Add. counter-weight*	Tyre inflation (29.5 R25)	Equipment with teeth
+1.000	+1.900	+250
+1.640	+2.434	-360
+1.380	+2.100	-360
+1,141	-	-

* Standard for High-Lift

TECHNICAL DATA



ENGINE

Type Komatsu SA6 D140 E-3
water-cooled, 4-stroke, turbocharger

Rated capacity 235 kW/315 HP (SAE J1349)
at engine speed 2.100 rpm

Torque/engine speed max. 1.373 Nm/1.400 rpm

Number of cylinders 6

Bore/stroke 140/165 mm

Displacement 15,2 l

Injection system Common rail, map-controlled

Lubricating system Gear pump, forced-feed lubrication

Filter Full-flow filter

Electrical system 24V

Battery 180 Ah

Three-phase alternator 50 A

Air filter type Dry-air filter with automatic dust emission and preliminary purification including a dust display



TRANSMISSION

Torque converter One-stage, one-phase, 3 element

Transmission Automatic planetary powershift gearbox

Travelling speeds in km/h

Gear	1st	2nd	3rd	4th
with 26.5 R25 tyres:				
forwards	6,7	12,0	20,2	33,0
backwards	7,5	13,4	22,5	36,1
with 29.5 R25 tyres:				
forwards	7,1	12,6	21,2	34,8
backwards	7,9	14,1	23,5	38,1



CHASSIS AND TYRES

System 4-wheel drive

Front axle HD planetary drive axle, fully floating

Rear axle HD planetary drive axle, 15° swivel angle

Differential Straight bevel gear

Final drive Planetary gear in oil bath

Tyres 29.5 R25 L-3, standard
29.5 R25 L-2/3, L-4, L-5
26.5 R25 L-2/3, L-3, L-4, L-5



STEERING SYSTEM

System Articulated frame steering

Type Fully hydraulic power steering

Steering angle to either side 40°

Steering pump Gear pump

Working pressure 210 bar

Pumping capacity 172 l/min

No. of steering cylinders 2

Type Double-action

Hole diameter x stroke 110 x 486 mm

Smallest turn (outer edge of the tyre 29.5 R25) 6.530 mm



BRAKES

Service brakes Fully hydraulic dual-circuit system,
running in oil bath
Multi-disc brakes
on all wheels,
maintenance-free

Parking brake Electrohydraulically operated,
running in oil bath
multi-disc brake,
maintenance-free

Emergency brake Uses parking brake



HYDRAULIC SYSTEM

Hydraulic pump Gear pump

Working pressure 210 bar

Circulating capacity of hydraulic pump 348 l/min

Number of lift/bucket cylinders 2/1

Type Double-action

Bore diameter x stroke

Lift cylinder 200 x 839 mm

Bucket cylinder 225 x 613 mm

Hydraulic control lever Pilot-controlled, 2-levers

Hydraulic cycle time with rated load bucket filling

Lifting time 6,4 s

Lowering time (empty) 3,5 s

Dumping time 1,7 s



SERVICE REFILL CAPACITIES

Cooling system 99 l

Fuel tank 460 l

Engine oil 37 l

Hydraulic system 175 l

Axle (front and rear axle) 78 l

Torque converter and transmission 62 l



CABIN

Two-door cabin in conformity with ISO 3471 with ROPS (roll over protective structure) in conformity with SAE J1040c and FOPS (falling object protective structure) in conformity with ISO 3449.

The air-conditioned pressurised cabin is mounted upon hydrobearings and is noise dampened.

The noise level in the cabin is 77dB(A) in accordance with the dynamic measurement in conformity with the EU standard 95/27/EC.

STANDARD EQUIPMENT

- | | | | |
|---|--|--|---|
| <ul style="list-style-type: none"> • Universal bucket 5,0 m³ (SAE, heaped) • Automatic return-to-dig • Automatic boom kick-out • Central lubrication system • 29.5 R25 L-3 tyres • Heavy-duty axles with planetary reduction gear in wheel hubs • Electronically controlled ECMV automatic transmission • Fully hydraulic brake system • Spacious double door driver's cab to DIN/ISO | <ul style="list-style-type: none"> • ROPS/FOPS frame to SAE • All-round tinted glazing • Air conditioning • Air-cushioned comfort driver's seat • Seat belt (EU standard) • Servo-operated 2-lever hydraulic control • EDIMOS II monitor system with self-diagnostic function • Stereo cassette radio • 2 halogen main headlights • 2 spotlights at front and rear | <ul style="list-style-type: none"> • Reversing light • Handrails on left/right • Emergency steering system • Vandalism protection • Back-up alarm • Horn | <p>The WA500-3 is equipped in compliance with the safety regulations of the machinery guideline with its emission reference values corresponding to the stipulations of the International Standard ISO 6393 and the EU Directive Stage II</p> |
|---|--|--|---|

OPTIONAL EQUIPMENT

- | | | |
|---|---|---|
| <ul style="list-style-type: none"> • High-lift equipment including high-lift counterweight • Additional counterweight 1.000 kg • Limited-slip differential (LSD) front and rear • Electronically controlled, load stabilizer (ECSS) 2nd generation • 29.5 R25/26.5 R25 tyres (L2/3, L3, L4, L5) • Tyre guard chains • Universal bucket 4,5 m³ • Universal bucket 5,5 m³ • Trapezoidal rock bucket 4,5 m³ • Trapezoidal rock bucket 5,0 m³ | <ul style="list-style-type: none"> • Heavy-duty versions • Various tooth systems, BOC, segments, blade savers (Hensley™/KVX™) and other optional bucket accessories • Quick coupler • Log grapples • Special buckets • Joystick steering with integrated F/R transmission function • Payload meter • Transmission guard • Engine preheating • Beacon light • Auxiliary lights front/rear | <ul style="list-style-type: none"> • Front screen protective grid • Cab air safety system • Exhaust gas particles filter • Turbo II pre-filter • Electronic anti-theft lock • Battery main switch • Biodegradable oil for hydraulic system • Special paintwork • Heated rear window • Wastehandler specification • Steel handler specification • Tunnel specification <p>Further equipment on request</p> |
|---|---|---|

KOMATSU

www.komatsueurope.com